

Aquablu®

Manual

Aquablu One

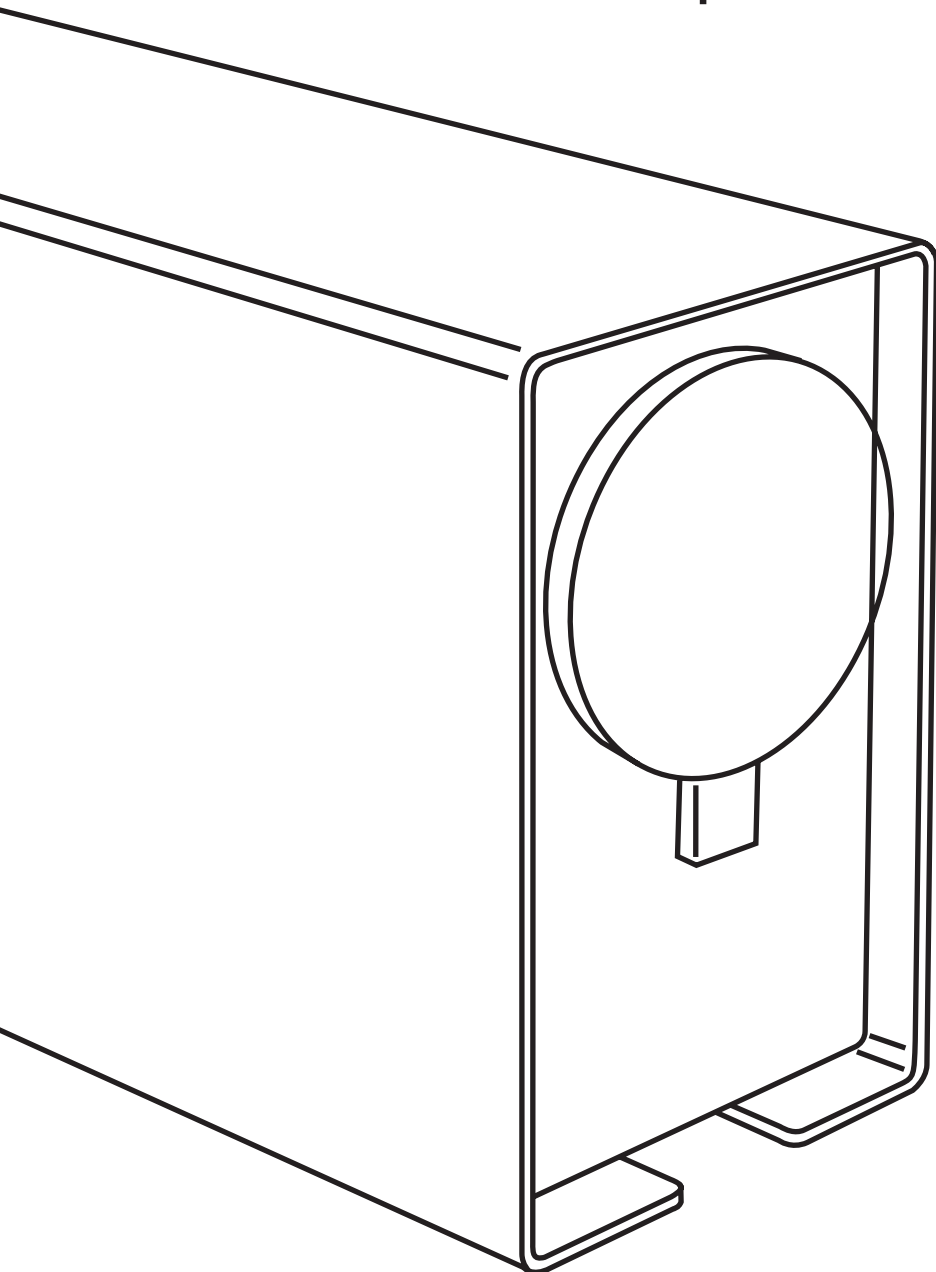

Manufactured in The Netherlands

Dear Customer,

Thank you for purchasing this Aquablu purification system.

The system is designed and produced in the Netherlands with great care and attention. Ease of installation, maintenance and use with a minimum of electrical power consumption and maximum sustainability were the leading design parameters and we are confident you like the result.

Best regards from the Netherlands,

The Management and Staff of Aquablu

ABOUT THIS MANUAL

In spite of its simplicity, it is essential that the system is correctly installed, maintained and used. Please allow yourself sufficient time to read and understand this manual, before you install, maintain or use the Aquablu One. With proper installation and regular maintenance, the system will provide many years of reliable service, protecting you and your family.

Failure to adhere to the information provided in this manual may lead to significant risks for the health and safety of people or damage to goods.

STORAGE, USE AND TRANSFER OF THIS MANUAL

This manual, and other relevant documentation (such as proof of purchase, inspection and maintenance records) must be kept in a suitable and safe location for future reference. If a change of ownership occurs during the lifetime of the machine, make sure all relevant documents are transferred to the new owner.

In case the manual is lost, a replacement can be downloaded from www.aquablu.com. Downloading the manual ensures that the latest information on the system can be obtained. This manual reflects the technical specification of the system at the time of writing. The manufacturer reserves the right to amend and extend the contents of the manual to reflect the technical progress of the purification system, without rendering this publication obsolete. Contact the Aquablu technical department in case further information is needed about maintenance and repair.

We encourage our customers to share their suggestions about this manual and the product with us. Please send an e-mail to info@aquablu.com with your remarks and observations.

Table of content

Health and Safety instructions	4
What is in the box?	5
How does it work?	9
What is under the bonnet?	11
System overview	12
How does it communicate?	13
Installing your Aquablu One	17
- Mechanical Installation	17
- Hydraulic Installation	20
- Electric Installation	23
- Commissioning	24
Using and supervising the system	25
Troubleshooting the system	27
Servicing the system	31
Service history	36
Decommissioning the system	37
Warranty	38
Declaration of conformity	40
The small print	41

REQUIRED SKILL LEVEL

There is no need for the person who installs the system to be an accomplished plumber.

Understanding how the system works and is installed and some DIY skills are however needed for a successful and reliable installation.

REQUIRED TOOLS AND MATERIALS

Only some basic tools (screw drivers, electric drill, pliers, etc.) found in most homes will be required. In addition to the fasteners supplied in the kit, specific fasteners may be needed to suit your specific installation, depending on the surface the components are to be mounted on.



DANGER / WARNING

This symbol indicates situations of serious danger which, if ignored, may result in serious risks to the health and safety.



IMPORTANT

This symbol indicates important and technical information.

Health and safety instructions

YOUR HEALTH AND THE PURIFICATION SYSTEM

The system is processing future drinking water and therefore, good care and cleanliness is required while installing and/or maintaining the system to prevent potential health risks. In particular the introduction of any polluting or contaminating materials into the system during the replacement of the membrane filter insert must be prevented.



Always wash your hands carefully when replacing filter inserts or filter cartridges to avoid the introduction of undesired materials into the filtering system.

SAFETY INSTRUCTIONS

- Please read the instructions carefully and keep them in a safe place.
- The operator must understand the instructions before operating the purification system, and must follow all safety and operational guidelines.
- The system is intended for purification of fresh water from any source that is considered potable.
- Only use the system for the intended purpose.
- In spite of the system complying to the applicable rules and safety regulations for electrical machinery, there is always risk of injury when using electrical systems improperly.
- The voltage of the power source must be the same as specified on the rating plate of the power converter unit supplied with the machine.
- Make sure there is an earth leakage switch or automatic current differential switch in the power line to the filtering system. (e.g. 30 or 500mA).
- Do not pull the power cable over sharp edges, clamp it into place or allow it to hang down. Keep the cable away from hot and damp areas and abrasive surfaces.
- Check the system at regular intervals for damaged or defective parts. The system should not be used when it shows any visible damage, or has damage to components or any other conditions that may affect its safe operation.
- Have any damaged or defective parts repaired or replaced by an authorized Aquablu dealer. Improper repairs can cause considerable danger.
- Never attempt to remove or replace any parts other than those specified in this manual.
- Do not open/remove the plastic cover of the purification unit. Only authorized Aquablu dealer may take system components apart, unauthorized opening of system components makes any warranty void.
- Before performing any maintenance work on the filtering system, ensure that the power supply is switched off and disconnected.
- Do not operate a purification system that has not been properly maintained or equipped.
- Do not mount any purification system components on unsafe or unstable surfaces.



This Aquablu equipment does not have an ATEX certification and must NOT be operated in hazardous or potentially explosive environments.

MAINTENANCE

The operational safety and efficiency of the purification system is largely dependent on the observance of the indications provided by the system and the instructions in this manual. Pay in particular attention to the following points:

- Only operate the purification system within the operational limits.
- Take corrective and/or maintenance action immediately when prompted or required.
- Only use original Aquablu replacements and spare parts.
- The instructions in this manual are not a substitute for, but a supplement to the applicable local health and safety regulations.

What is in the box?

GENERAL

The Aquablu One purification system consists of four main components.

- 1) The pre-filtration unit
- 2) The purification unit
- 3) Power adapter for the purification unit
- 4) Mineral cartridge (optional)
- 5) The water faucet

The box also contains the fitting, connection and mounting materials required to complete a standard under sink installation. This includes the documentation needed to install, maintain and use the system. See the packing list for a full listing off all materials supplied and check for completeness before starting the installation.

1. PRE-FILTRATION UNIT

The pre-filtration unit is selected to be compatible with the feed water available on site. Physical appearance and installation are the same. The filtration unit consists of two separate filters, attached to a communal connection block. All parts are made from engineering plastics suitable for drinking water systems. See figure 1a for appearance of the filtration unit.

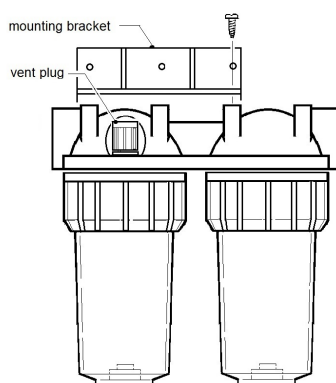

Fig. 1a: Pre-Filtration Unit

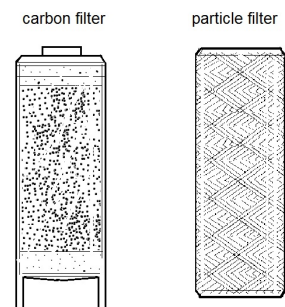

Fig. 1b: Pre-filtration elements

The standard inserts of the pre-filtration unit are one activated carbon cartridge and one string wound filter which prevent any particles larger than 5 micron and chlorine to harm the membrane. See figure 1b for their identification. The filters can be easily removed for replacement purposes. The pre-filter is installed between water supply and the purification unit. The unit has a dedicated direction of flow, which cannot be reversed.

2. PURIFICATION UNIT

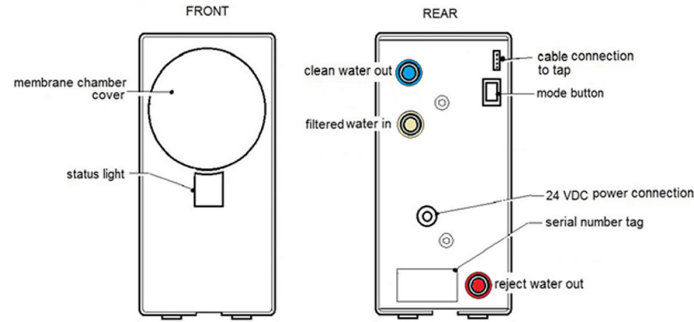

Fig. 2: Purification unit

The purification unit is housed in a stainless steel frame, enclosed by a plastic cover. The cover must not be removed, other than by an authorised Aquablu dealership. Unauthorized removal makes any warranty void.

On the front of the cabinet the cover for the membrane chamber is present, as is the status light.

On the rear of the unit the water and electrical connections are located together with the “mode” button. All control and processing equipment is contained inside the enclosure.

SERIAL NUMBER TAG (UNIT ID)

Each system can be identified by means of a Unit ID (serial number) which can be found by making contact with NFC using your Aquablu phone app. If no phone is near you the serial number tag can be found at the bottom of the system. See Fig. 3 for the appearance of the tag.



Fig. 3: Serial number tag

Always include the Unit ID of the unit in all communication with your dealer or Aquablu service department when requesting support or spare parts.

When requesting support for a technical issue, make sure the trouble shooting procedure in de Aquablu app has been consulted and followed first.

3. POWER SUPPLY UNIT

The purification unit is powered by a 24 Volt DC Power adapter that can be supplied for a number of different AC supply voltages. Before connecting the adapter to a wall socket or other AC supply, check the label on the bottom of the supply unit for the required AC input voltage. See Fig. 4 for the location of the mains data.

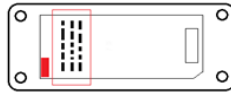

Fig. 4 Bottom view of DC power supply with location of AC supply data

It is essential that the supply voltage indicated on the power adapter is the same as the voltage coming out of your wall socket or other AC supply.

The power adapter is fitted with a ca. 1,5-metre-long (removable) mains cable, and a permanently fixed device cable of ca. 1,1 metres long. The physical appearance of the mains cable plug will differ depending on your local mains interface. See Fig. 5 for the appearance of the DC power adapter and the cables.

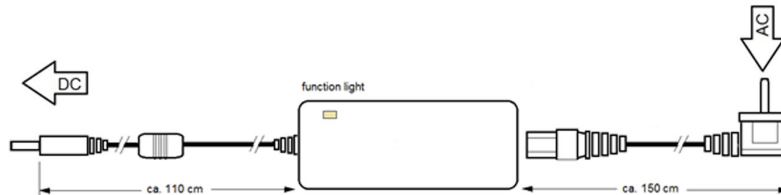

Fig 5: DC Power Supply

4. MINERAL CARTRIDGE (OPTIONAL)

The mineral cartridge consists of one canister that contains essential minerals that can be added to the filtered water to enhance the taste and add beneficial minerals (PH level) to your purified water. All parts are made from engineering plastics suitable for drinking water systems. The mineral cartridge must be installed between the purification unit and the water faucet and can be found in Fig. 6.

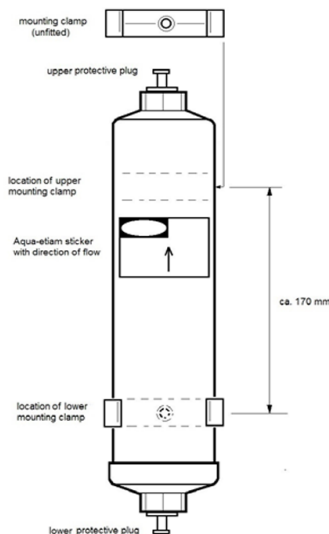

Fig 6: Mineral cartridge

5. THE WATER FAUCET

The water faucet is a sink level controllable water outlet, specifically designed to work with the Aquablu purification system. The faucet is supplied in a separate box that contains the faucet, a mounting console and hardware. In the faucet a circular signal lamp is fitted to inform the operator about the status of the purification system. See Fig. 7 for the appearance of the Aquablu LED Faucet.

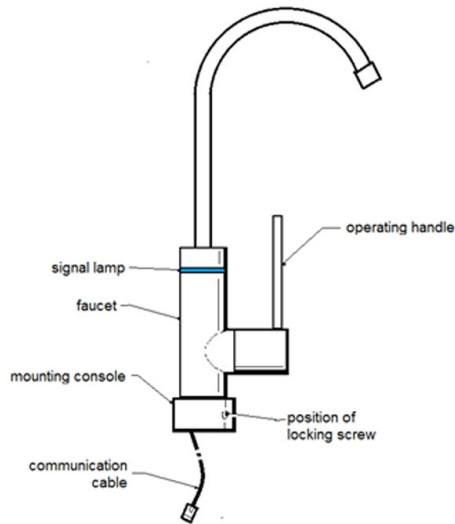

Fig. 7: Aquablu LED Faucet

OTHER MATERIALS PROVIDED IN THE INSTALLATION KIT

- 4 meters of 10 mm diameter food quality hose
- 1 meter of 6 mm diameter food quality hose
- Clamps and screws for mounting the re-mineralization unit
- Screws for mounting the filtration unit.
- Fitting for connecting the feed water hose to a G 3/4" threaded mains water tap
- Pressure regulator
- Fitting for connecting the reject water hose to a G 3/4" drain connection
- Assorted 3/4G fittings for connecting the system to the domestic feed water supply and the domestic drain system

How does it work?

SYSTEM DESCRIPTION

PURIFICATION TAKES PLACE IN TWO STAGES.

1. During the pre-filtration stage an active carbon filter removes unwanted odors or tastes (and within specified limits chlorine and volatile organic compounds) and a 5-micron preliminary filter that filters out grains and other large particles.
2. After having passed through the pre-filtration unit, the water is pushed into the purification unit to an electric pump, which pumps the water under high-pressure (6 bar) through the membrane filter.

In the membrane filter, two separate water streams are generated.

1. A purified water stream, which is, led to the conductivity and flow meters, and then leaves the purification unit.
2. A reject water stream that leaves the purification unit through the reject water outlet.

The purified water stream is led to the mineral cartridge and from there to the water faucet; the rejected water is led into the domestic drain system.

MEMBRANE PURIFICATION AND REGENERATING PRINCIPLE

The following happens during the purification process:

1. After pre-filtration the pressure of the water is increased to 6 bar before being pressed through the membrane.
2. As the feed water is pushed through the membrane filter, the suspended dissolved pollutants collide with the membrane tissue and stick to it. Effectively removing all harmful contaminants in the water.

* The reject and our automated back-flush enables the system to take care and clean itself. This enables a longer membrane lifetime while ensuring only the highest quality of pure water to leave the system.
3. During the process the pressure of the water is reduced to 2 bars which is also the pressure at which the pure water leaves the system.
4. Optionally, before reaching the tap the water can be mineralized using our mineral cartridge.

CONTROLLING THE PROCESS

When the system is powered up, and a correct feed water pressure (between 2 bar and 6 bar) is detected, the solenoid valve in the feed water inlet tube is opened, and water from the filtration unit fitted between the feed water source and the purification unit is admitted to the purification unit. At this entry point also a temperature sensor and a non-return valve are fitted.

From the entry point the feed water is pushed under feed water pressure to an electrical pump that forces the feed water under high pressure through the membrane. Pump pressure is monitored in the pressure line to the membrane, while pump motor current is also measured as a process parameter.

Once the purified water is through the membrane its temperature, electro-conductivity and flow rate are measured to monitor the quality and quantity which determines the membranes condition.

A pressure regulator provides the correct back-pressure in the reject stream to reach the nominal pressure on the membrane. During a flush an additional solenoid valve opens a by-pass channel which makes it possible to use the full pump pressure. All flushes are automatic but can also be initiated manually.

All sensors and valves are contained in the measuring and control block that also houses a CPU that translates pressure and temperature into digital information. From the purification unit the water is led through the mineral cartridge (optionally) and from the mineral cartridge to the water faucet. See figure 8 for an explanation of the valve block.

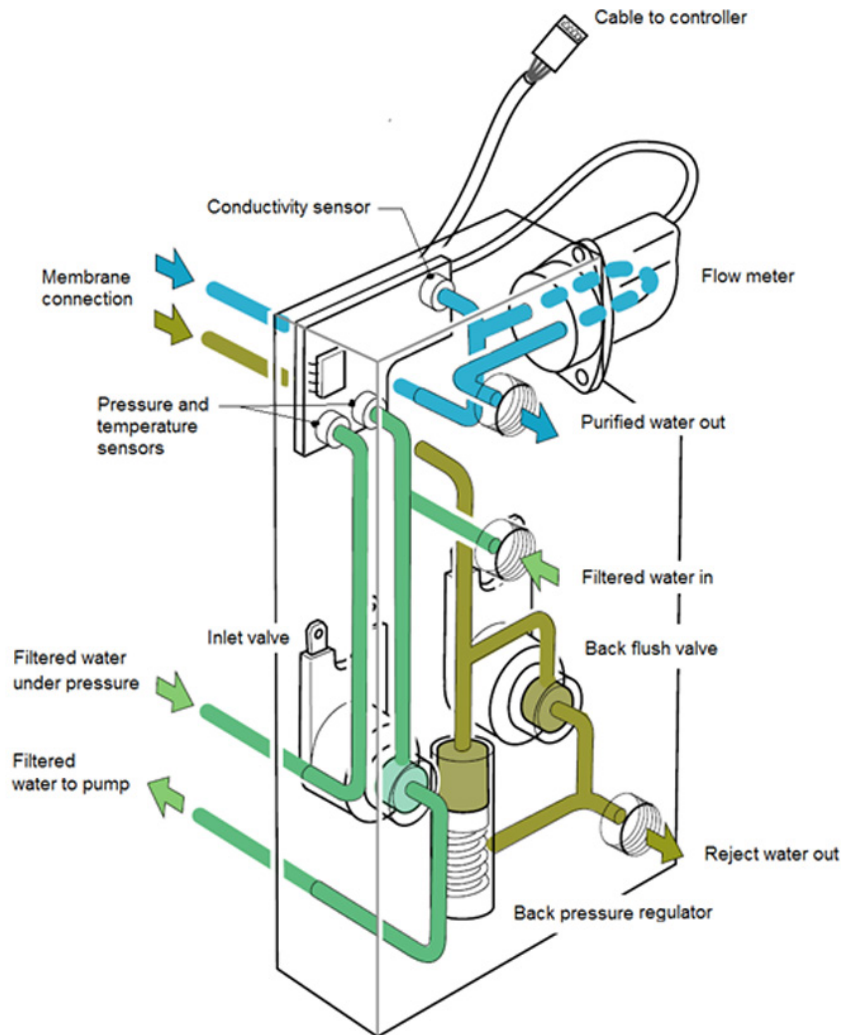

Fig. 8: Valve block

What is under the bonnet?

To give an impression of the relative simplicity and compactness of the Aquablu One, see figures 9a and 9b below for an overview of the major components in the unit.

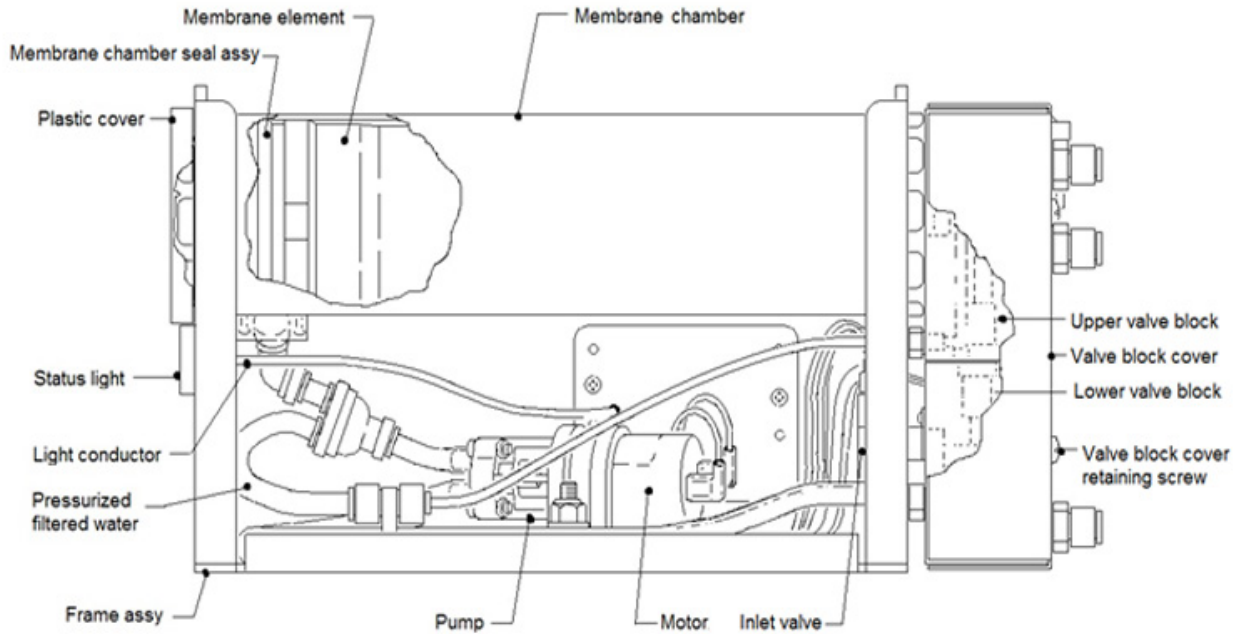

Fig. 9a: Right hand side view of unit with the outer cover removed

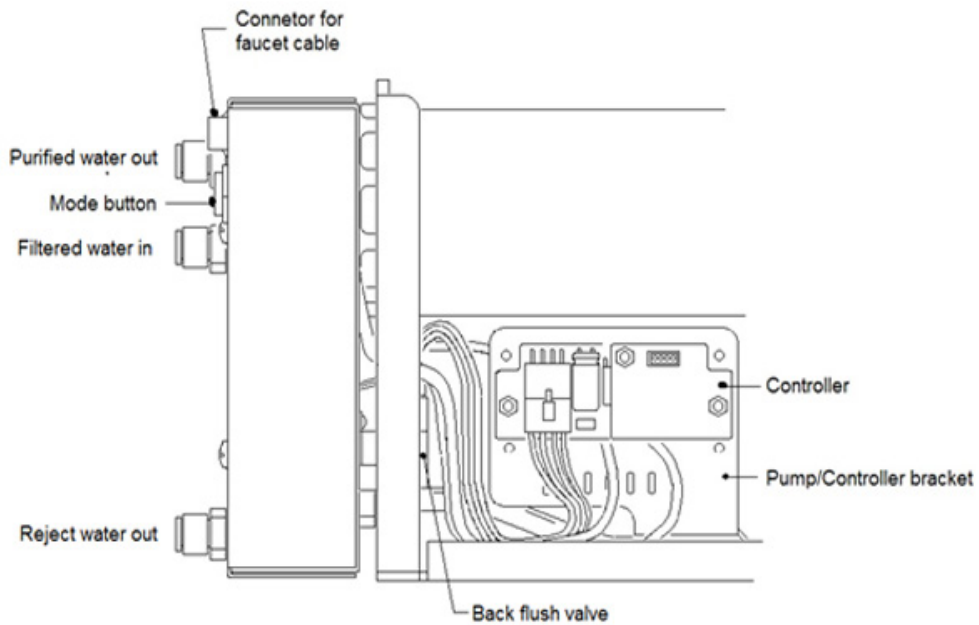

Fig. 9b: Left hand partial side view of unit with the outer cover removed

System overview

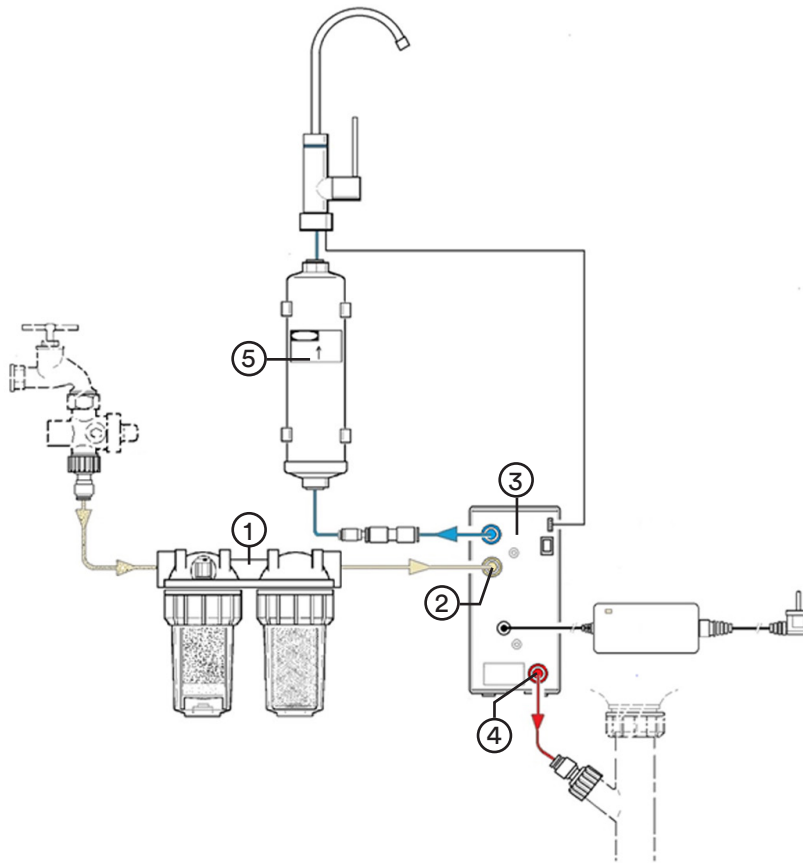

Fig. 10: System overview

- 1) The raw water enters the pre-filtration kit in order to remove large contaminants (5 micron).
- 2) The water enters the system and is pressurized over our unique spiral wound membrane. Customisable to every raw water quality, our membranes remove contaminants up to 0.0001 microns in size. This includes viruses, antibiotics and micro-plastics.
- 3) By monitoring flow, quality, pressure and temperature of your water, our systems give you insight into the quality of your drinking water. NFC allows information readout through our Aquablu app and ensures worldwide service and system control.
- 4) Rejected water flows out of the system.
- 5) Before the water reaches the tap, there is an option to add extra minerals using our mineral cartridge to ensure great taste (Alkaline 8).



In water mains fed systems, the reject water may under no circumstances be fed back into the system! Not observing this may cause a serious health hazard to the water mains system! Discard the reject water in the sewage system or (preferably) in a grey water system.

How does it communicate?

Simple communication between any machine and its user is the basic rule to gain trust in technical equipment. Understanding that not all Aquablu owners are chemical engineers nor masters of fluid technologies, simple communication is one of the corner stones of our development.

Smart communication via NFC enables you to get direct insights into the technical status of your system and the water quality at any moment of time. The read out is performed using the Aquablu app. The more scans you perform the better it allows you to share the responsibility for the maintenance directly with your local Aquablu service partner without any additional costs or effort. On top of that, the Aquablu One is also fitted with a multi color light and a LED indication on tap level which indicate the system status in a more conventional way.

NFC (NEAR FIELD COMMUNICATION)

The CPU of the purifier controls over 96 parameters and thereby monitors the water quality as well as the technical status of the system. This data can be read out by holding the Aquablu app close to the NFC sign on the left side of the Aquablu One casing. The NFC will launch the service web page and will provide you with a list of all vital information. Subsequently, the whole list of 96 parameters is sent to your local Aquablu service partner, as well as to the Aquablu HQ. This information allows technical insight into the system and determines if any physical maintenance is required.

In order to activate the NFC in your smartphone, you must download the Aquablu app in the IOS or Google play store.

MAKE SURE YOU HAVE THE LATEST VERSION OF THE AQUABLU APP INSTALLED

Download: [Google Play Store](#)

Download: [Apple Store](#)

1 INSIGHT INTO THE WATER QUALITY

Simply scan the NFC chip and let the App give you insight into the quality of your drinking water.

2 AN OVERVIEW OF YOUR PURIFIERS

Check and compare the results for each system.

3 HELP WITH TROUBLESHOOTING

No need for thick manuals or unnecessary maintenance visits. The answer is right in your hand.

4 OFFLINE & ONLINE

The NFC does not require internet, allowing the dealer to service the system in remote locations. The App automatically sends the info when back online.

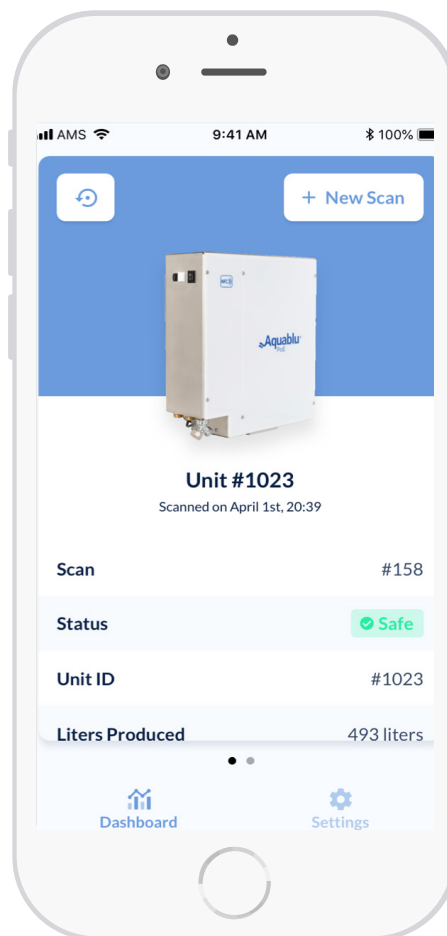

How does it communicate?

DESCRIPTION OF CONTROLS AND VISIBLE AND AUDIBLE SIGNALS

See figure 11c below for the location of the controls

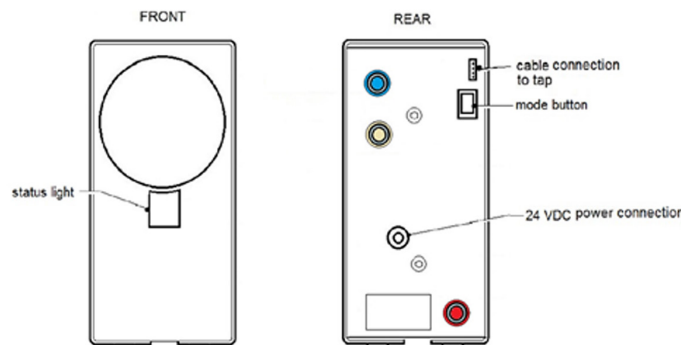

Fig. 11: Overview of controls

Once the Aquablu One is connected to the power adapter it is always “on”. Therefore the only way to completely turn off the system is by disconnecting the 24 V DC power adapter.

If the system is running as intended it can remain “on” indefinitely. However, some errors and part replacements may require a full restart which is initiated by interrupting the electrical supply and reconnecting the machine to the power adapter.

If the purification system requires attention, the blue light on the water faucet starts to flash red. A flashing blue light at the faucet indicates that the system is performing a flush, flashing blue during production indicates a warning of low quantity or quality of the permeate water.

The purification unit itself communicates its status by means of the status light on the front of the unit, and by audible signals. This can be used in case you do not have a phone near you. However, we always recommend to use NFC to make connection between the Aquablu app and the system to communicate with your Aquablu product.

To provide detailed communication, both the status light and the audible signalling have a range of different signals available. Light signals are used for normal communication, and audible signals are only used in “emergency” situations, where immediate action of the operator is required.

VISIBLE SIGNALS

The status light can show different colours in differing patterns to indicating the status of the unit. The possible colours are:

White ○ Green ● Yellow ● Red ● Purple ●

The available patterns are:

Steady ○

Single flash ○))))))))

Double flash ○))))))))

Triple flash ○)))))))))

Quintuple flash ○)))))))))))))))

Quick flash ○)))))))))))))))))))))

The default “no problem” standby status is a steady green light.

Audible signals

Audible signals are only used in “emergency” situations, where immediate action of the operator is required. The possible sound patterns are:

Constant ((—————))

Intermittent ((●))(●)

Quick ((●))(●)(●)(●)(●)(●)

The different error codes and required actions can be found on page 27-30.

Installing your Aquablu One

The installation of the system can be divided in four stages:

- 1) Mechanical installation
- 2) Hydraulic installation
- 3) Electrical connection
- 4) Commissioning

1. Mechanical installation

The mechanical installation consist of installing the filtration unit, the mineral cartridge and the LED water faucet. Make sure to install all components, hoses and cables in such a manner that they are not in contact or exposed to a heat source.

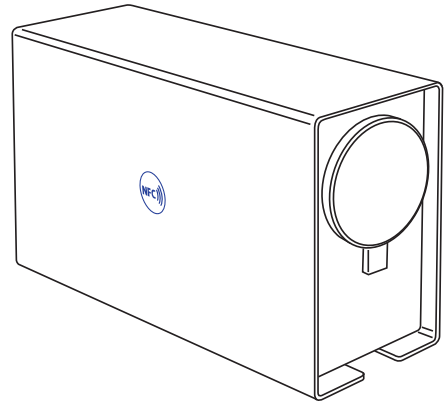

1.1 PRE-FILTRATION UNIT

The filtration housing has mounting holes on top to which the blue mounting plate supplied in the set must be attached. Make sure to install it that way that both vent plugs can be reached. For this purpose three screws of the correct diameter and length are supplied. It is imperative only these screws, or screws with identical dimensions (15 x 3), are used to prevent damage to the filter housing.

The mounting plate can be attached to the filter housing from both sides according to the available space underneath your sink. The direction of flow is indicated on the housing. See figures 12a and 12b below for a visual reference.

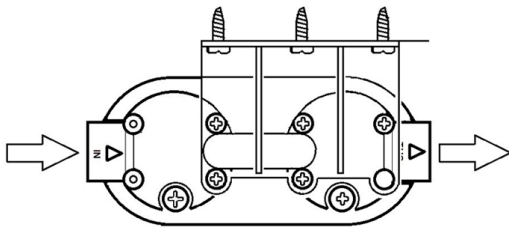

Fig. 12a: Right hand bracket mounting

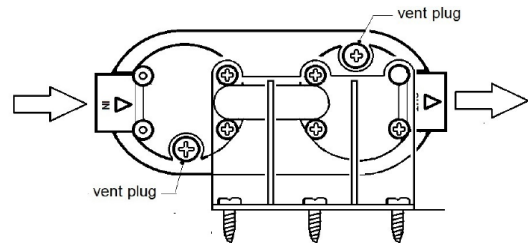

Fig 12b: Left hand bracket mounting

With the mounting plate fitted to the top of the filtration unit, the unit must be attached to the appropriate side of the cabinet. Keep in mind that the vent plugs must be accessible. The unit must be located in such a way that the clear plastic filter containers can be removed later for installing and/or changing the filter elements. The unit must be located in such a way that the connecting hoses can be fitted without sharp bends or kinks.

Please install the unit as close to horizontal as possible.

It is advised to fit both filter cartridges to the unit at this stage. The black cartridge (activated carbon) must be closest to water source, the white cartridge between the black cartridge and the purification unit. Flush out excessive carbon dust from the activated carbon cartridge under your standard faucet before inserting the cartridge in the filtration unit.

1.2 MINERAL CARTRIDGE

The mineralization unit is held by two clamps that are attached to the appropriate side of the cabinet, just underneath the faucet. To avoid unwanted air bubbles, it has to be installed vertical. The unit must be located in such a way that the connecting hoses can be fitted without sharp bends or kinks.

1.3 WATER FAUCET

1. First determine the correct mounting location of the water faucet on the sink. The fitting instructions are only applicable to the water faucet supplied with the kit. Other faucets must be installed according to the instructions supplied with that faucet.

2. After correctly determining the location a 20 mm diameter hole must be made. It is advised to use a 20 mm hole saw to cut the required hole. See Fig.13a for an illustration of a hole saw. Smoothen the edges of the hole and remove all debris and sawdust in the cabinet.

3. The sealing plate, the mounting socket and the collapsible anchor must be assembled as shown in the figure 13b below.



Fig 13a: Hole saw example

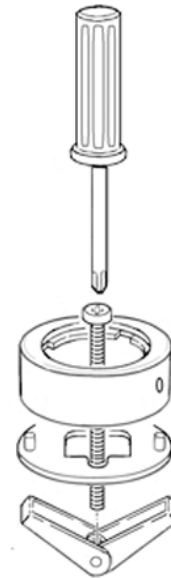

Fig. 13b: Pre assembly of mounting socket

4. Push the assembly through the hole in the sink, unfold the collapsible anchor and rotate the anchor into a position that offers a flat and rigid surface.

5. Rotate the mounting socket with the cam lock coupling in such a position that the water faucet is in the correct position when locked into the mounting socket. Use the hole with the locking screw as reference.

6. With the anchor in position, the central Phillips head screw must be tightened until the mounting socket is firmly fastened to the sink.

NOTE:

It is advised to insert the water hose that connects the water faucet with the mineral cartridge into the push-in coupling of the water faucet before you fix it to your sink. Once installed, the fitting can be difficult to reach. See chapter "Hydraulic installation" for further instructions.

7. Insert the water faucet hose and electrical cable through the hole in the mounting socket. Make sure the hose and the cable run smoothly through the socket and the hole.

8. Place the water faucet body onto the mounting socket, in such a way that the locking cams on the lower faucet body line up with the apertures in the mounting console, as shown in figure 14a.

9. Push the faucet body onto the mounting console and rotate counter clock to lock the faucet body in the console, as shown in figure 14b. Do not force the connection, if unreasonable forced is required, check if anything is wrong and retry.

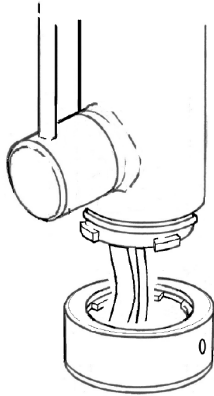

Fig.14a: Placing faucet on mounting socket

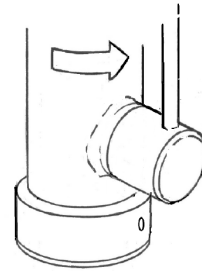

Fig.14b: Faucet in locked position

10. With the faucet body correctly fitted to the mounting console, the body must be secured to the console by means of a locking screw. See the figure below for the final situation, and the location of the locking screw.

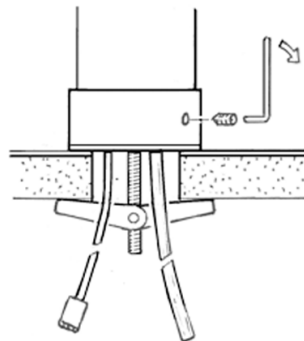

Fig.15: Correctly mounted water faucet

11. Turn the screw in with the Allan key provided until tight. Please do not over tighten the screw to prevent any accidental damage.

12. The mechanical installation of the water faucet is ready.

2. Hydraulic installation

HOSE PREPARATION

It is essential the hoses are cut off as straight as possible to prevent leakage. After cutting, any rough edges need to be removed and the cut needs to be cleaned. Beveling the hose ends slightly will aid the assembly. Use a sharp knife or scissor to prevent crimping of the hose. Make sure to install all hoses in such a manner that they are not in contact or exposed to a heat source.

HOSE LENGTHS

With the components fitted and placed in their respective final locations, the hose lengths can be determined. The hoses must be dimensioned in such a way that they can be fitted to the individual components without sharp bends, kinks or over-stretching. Allow for over length to move the unit when the membrane needs to be replaced. In case the hose sections supplied in the kit are not sufficient to complete the installation as is explained in this manual, extra hose might be required. Make sure that, when purchasing extra hose from external sources the hoses are of the correct diameter and are genuine food quality.

Two types of connections are used in the installation.

1. Push-in connections

With push-in connectors, the correctly prepared hose is simply pushed into the coupling. Pushed in sufficiently, the hose will bottom on a ridge inside the coupling (Fig. 16a).

After the hose bottoms, the hose must be pulled backwards (away from the connector) to lock the coupling. Pulling back the hose also pulls back the locking ring on the coupling, and with the hose firmly pulled back a leak free connection has been made (Fig. 16b).

The hose can be removed from the coupling by means of pushing the locking ring in and at the same time pulling the hose out (Fig. 16c).

It is advised to closely inspect the hose for damage after removal before using it again. In case of doubt the damaged or suspect section must be cut off. See figures below for push-in coupling handling.

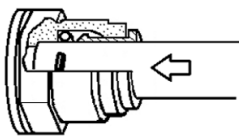

Fig. 16a: Inserting the hose

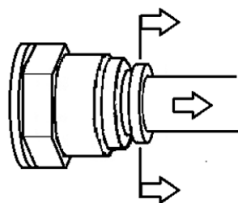

Fig. 16b: Locking the hose

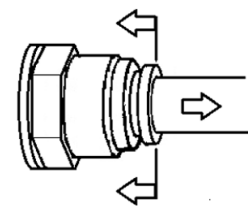

Fig. 16c: Removing the hose

2. Screw on connections

With the kit two of screw/push-in connectors are supplied to connect the system to the water supply, and to the drain system. See figure 17 below for their appearance and application.



Fig. 17: Screw on connection

WARNING!

INSTALLATION IN AREAS WITH MAINS PRESSURE ABOVE 3 BAR

In areas with a mains pressure above 3 bars, a pressure reducer **MUST** be installed to prevent damage to the equipment. The pressure reducer must be installed directly onto the mains supply tap, to ensure the water pressure on the pre-filtration unit does not exceed the 3 bar maximum. The screw/push in connector must be attached to the low pressure side of the pressure reducer. The pressure reducer can be bought at the Aquablu web shop.

INSTALLATION IN AREAS WITH LOW WATER PRESSURE BELOW 1.5 BAR

In installations where the pressure on the input side of the purification unit is below 1.5 bar, it is necessary to install a feed pressure pump that provides an input pressure between 1.5 and 3 bar.

CONNECTING THE WATER MAINS TO THE PRE-FILTRATION UNIT.

A threaded (G 3/4") / push-in connector is supplied in the kit to connect the pre-filter to the water supply. If the water supply has another connection, a suitable coupling must be sourced locally. In either case, a 10 mm diameter hose must be securely fitted to the push-in coupling side of the water supply. The other end of the hose must be securely fitted to the push-in coupling of the feed water port of the pre-filtration unit.

Make sure the hose does not apply any lateral or axial forces on components when installed. Make sure the connections are watertight.

CONNECTING THE PRE-FILTRATION UNIT TO THE PURIFICATION UNIT

The outlet connection of the pre-filtration unit and water intake connection of the purification unit are both 10 mm push in connectors. The 10 mm hose can therefore be connected between the pre-filtration unit and the purification unit.



All water connectors in the purification unit are closed off by means of plastic plugs. In order to install the hoses, the plugs must be removed.



The plugs are fitted at the factory after testing and fitting the unit with a conservation liquid to protect the membrane. The plugs must not be removed under any circumstances other than directly prior to the installation and commissioning of the system.

CONNECTING THE PURIFICATION UNIT TO THE MINERALIZATION UNIT (OPTIONAL)

The purification unit purified water outlet has a 10 mm push-in connector, the mineralization unit inlet has a ¼" mm push in connector, in the hose between the purification unit and the mineral cartridge (mineralization unit) the reducer provided in the kit must be fitted. See figure 18 for the appearance of the reducer.

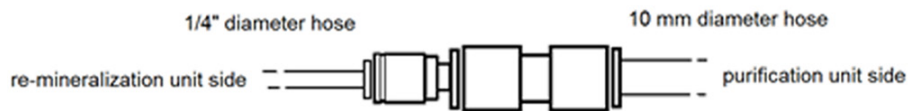

Fig. 18: Hose diameter reducer fitting

NOTE:

The mineralization unit has both connectors closed off by means of plastic plugs. In order to install the hoses, these plugs must be removed. The plugs are removed as shown in Fig. 16c. (page 22)

CONNECTING THE MINERAL CARTRIDGE TO THE WATER FAUCET

The mineral cartridge and the water faucet both have 6 mm push in connectors.

NOTE:

The push-in connectors of the re-mineralization unit are made of a slightly different material than the other connectors used in the system. A higher push in force is required to ensure a watertight connection. The hose is properly fitted when ca. 20 mm of hose is pushed into the connector.

CONNECTING THE PURIFICATION UNIT TO THE DRAIN

A threaded (G 3/4") / push-in connector is supplied in the kit to connect the system to the drain. If the drain system has another connection, a suitable coupling must be sourced locally. In either case, a length of 10 mm diameter hose must be securely fitted to the push-in coupling side of the coupling. The other end of the hose must be securely fitted to the push-in coupling of the reject water port of the purification unit.

3. Electrical connections

CONNECTING THE ELECTRICAL CABLE FROM THE WATER FAUCET

Push the multi pin plug of the electrical cable in the socket on the rear of the purification unit. Make sure to install all cables in such a manner that they are not in contact or exposed to a heat source and cannot be accidentally be pulled off the system.

See figure 19 below for an illustration of a completed purification system with all components arranged in the correct order.

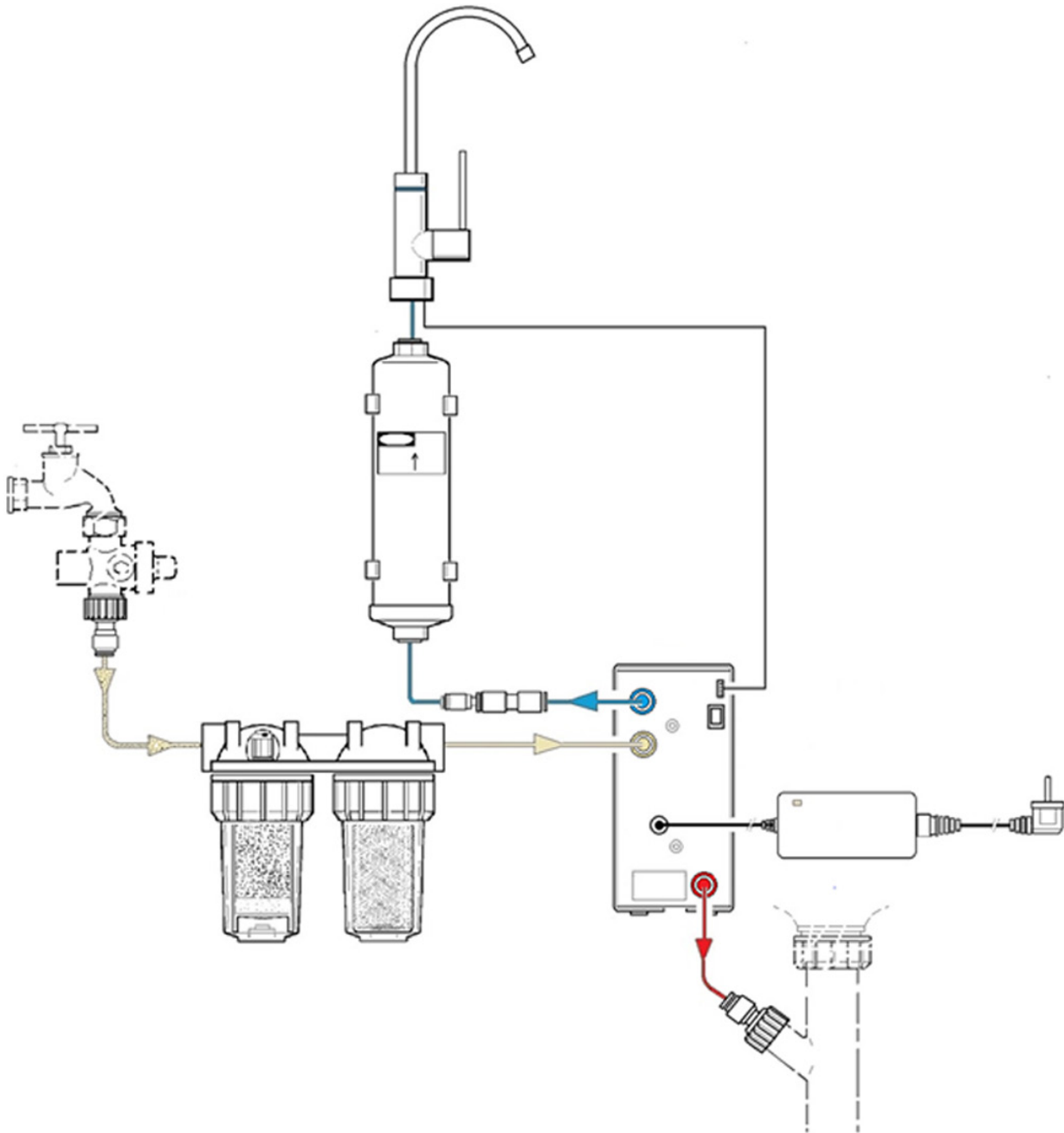

Fig. 19: System overview

4. Commissioning the system

Once all hardware components are installed the commissioning sequence can be started. Make sure that the DC power supply unit is plugged in on the mains side and the 24 volt plug is at hand, but NOT inserted in at this stage. The commissioning sequence below must be followed to letter.

1. Open the raw water supply valve underneath your sink.
2. Slowly fill the pre-filtration unit with water by slightly opening the vent plugs (Flathead screw on top of the filtration head) until it is completely filled. Follow this process with the second pre-filter, be prepared that there will be some water coming out. If the process is complete, fasten the vent plugs hand tight.
3. Open the Aquablu faucet.
4. Press and hold the mode button on the rear of the unit.
5. Insert the 24 VDC power plug in the power socket on the rear of the unit and hold the button pressed until you hear the pump motor starts. After applying power, the system will show a single flash in white, green, red, blue, purple, yellow. After flashing all colours once the pump will start up and a green single flash will be shown during the whole preparation and commissioning start (ca. 9-10 minutes). During the commissioning cycle the system switches between flushing (4x, water is discarded via the reject channel) and production (3x, water is dispensed from the faucet, do not close) to rinse out the membrane storage solution and any air which might have been accumulated while in transport.

* Due to air in the newly installed piping it is possible that the systems “low input pressure” alarm is triggered, the pump stops, faucet displays steady red and the control light on the unit show intermitted red while a peeping acoustical alarm is given. Repeat the sequence from step 4 onwards.

6. After approximately 10 minutes the control light on the unit will change to steady green and the water faucet needs to be closed within 30 seconds. A constant acoustic tone will indicate that the commissioning start is finished.
7. If you successfully close the water faucet within 30 seconds, the commissioning start is finished and the unit is standby and ready to use. The light on the water faucet will display a double flashing blue light.

* Failing to close the water faucet within the following 30 seconds, a yellow triple flash will be shown in combination with a steady audible signal, urging the operator to close the tap. Having closed the water faucet outside the 30 seconds available the machine will stop, the mode button on the rear of the unit must be pressed once, to initiate a bacteria flush (ca. 30 sec.) to ensure the safety of the purified water. After completing the bacteria flush operation a steady green light will be shown indicating that the commissioning start is finished.

8. If you have purchased a mineral cartridge the cartridge monitor must be set. It is set by the system to 9.000 liters and will count down as the water is being mineralized. Press the reset button three times (fast), open the faucet for 3-5 sec and close it. A steady green light will be shown on the unit, a steady blue light on the faucet.

Using and supervising the system



Using and supervising the system

Using the Aquablu system is convenient and easy as it only requires the use of the water faucet, and enjoying the safety and good taste provided by the Aquablu One unit.

The system is designed in such a way that routine checks and regeneration of the membrane is taken care of by the system itself.

During normal operation, the blue light on the water faucet will be illuminated, and the indications in the App will state “SAFE” and the indications shown will be visible on the purification unit.

INDICATION: 

Steady green light – Water faucet closed:

Status: Unit is ok, and in standby mode

INDICATION: 

Green single flash – Water faucet closed or open

Status: Unit is ok, but performing a membrane flush

Membrane flushing is started automatically when one of the following conditions is met:

- A) When production volume drops below 40 liters per hour for more than 6 seconds.
- B) When the water faucet has been opened and closed 75 times since the last flush.
- C) When 15 liters of water has been produced.

A system flush will reset both the faucet opening and water produced counter.

If during normal operation, the light on the water faucet will be illuminated in RED, you should scan the NFC chip and let the App give you the insights. If no phone is near you, the system status can be read out in a more conventional way using the status light on the purification unit.

Immediate attention is required if an audible signal is given in addition to a red light on the water faucet.

Blue flashing on the faucet indicates a flush when the system is in standby, blue flash while in production indicates “Warning” on water quality or quantity. The Indication light will flash yellow.

Please consult the Chapter “Trouble shooting” for the actions to be taken, or consult your local dealer immediately

Troubleshooting the system

THE APP

Trouble shooting has never been this easy! No need for complicated manuals or unnecessary phone calls. The answer to all your technical issues is right in the Aquablu app. By scanning the NFC chip with your phone you get all the insights into the system. When a problem may occur the App will guide and help you with the troubleshooting. By clicking on the info sign (i) in the “status” row in the App, it is able to explain you the problem (error code) and provide you with the steps necessary to solve any technical issue. Still need help with troubleshooting? No worries! Use your account to log into the app, make a new scan and communicate your Unit ID to your closest dealer or Aquablu HQ and we help you further. Always make sure to update the App to have the latest version.

VISIBLE SIGNALS SYSTEM

Troubleshooting may sound a bit daunting, but in most cases the troubleshooting consists of a quick inspection of the purification unit. See section “How does it communicate” for the signal combinations. The faucet lamp is designed to give real time information on the systems status. Such as standby, ready for production, Quality/quantity warnings and errors. Details are indicated in the app but also on the signal light on the front of the purification unit. If a red light is shown in combination with an audible signal, the Aquablu One must be inspected immediately for further indications.

INDICATION: 

Light on water faucet constant blue, Light on unit green,
water is available from faucet:

Status: Stand-by, ready for production.

INDICATION: 

Light on water faucet blinking blue , Light on unit green double flash,
water is available from faucet:

Status: Mineral cartridge depleted.

REQUIRED ACTION

Replace mineral cartridge and reset system (see “mineral cartridge exchange and reset” in the “Servicing the system “section)

INDICATION: 

Light on water faucet blinking blue while in standby, Light on unit green
blinking, no water available from faucet

Status: Bacteria flush, repeating every eight hours. After flushing the system goes back to standby.

INDICATION: 

Light on water faucet blinking blue while in production, light on unit blinking green, suddenly no water available from faucet

Status: Membrane flush. Triggered after five litre have been produced consecutively.

INDICATION: 

Light on water faucet extinguished, light on unit extinguished, no water available from faucet.

Status: Power failure

REQUIRED ACTION

Restore power supply. Unit will automatically start bacteria flushing when power supply is restored and auto-restores to standby.

INDICATION: 

Light on water faucet extinguished, light on unit steady green, water available from faucet.

Status: Electrical connection between faucet and unit interrupted.

REQUIRED ACTION

Restore connection or contact a service technician.

INDICATION: 

Light on water faucet steady red, light on unit is a red single flash in combination with a quick intermittent sound

Status: Low Feed water pressure.

REQUIRED ACTION

Restore correct feed water pressure and/or flow up to 2-6 Bar. Unit will automatically start bacteria flushing when pressure rises above the threshold level, and auto-restore to standby.

INDICATION: 

Light on water faucet steady blue, light on unit yellow triple flash in combination with a continuous sound

Status: Water production has run for more than 8.5 minutes.

REQUIRED ACTION

Close the tap. If not closed within 30 seconds the unit will stop automatically.

REQUIRED ACTION

Operator to interrupt power supply, and reconnect. The unit should automatically start bacteria flushing and auto-restore to standby. When this indication returns immediately after resetting a service technician should be called.

INDICATION: 

Light on water faucet steady red, purple light on unit in combination with continuous sound

Status: Internal leakage

REQUIRED ACTION

Operator to interrupt power supply, check for leakage if no water is detected, and reconnect. The unit should automatically start bacteria flushing and auto-restore to standby. When this indication returns immediately after resetting the supply of feed water should be closed off, and a service technician should be called.

MALFUNCTION INDICATIONS DURING WATER PRODUCTION AND/OR TRANSITION FROM STANDBY.

INDICATION: 

Light on the water faucet steady red, red Quintuple (5) flash in combination with continuous sound

Status: Pump over current

REQUIRED ACTION

Operator to interrupt power supply, and reconnect. The unit should automatically start bacteria flushing and auto-restore to standby. When this indication returns immediately after resetting a service technician should be called.

INDICATION: 

Light on water faucet steady red, red Triple (3) flash in combination with continuous sound:

Status: Pump pressure to high

REQUIRED ACTION

Operator to interrupt power supply, and reconnect. The unit should automatically start bacteria flushing and auto-restore to standby. When this indication returns immediately after resetting a service technician should be called.

INDICATION: 

Light on water faucet steady red, red Single (1) flash in combination with continuous sound

Status: Feed water temperature too high (over 40°C)

REQUIRED ACTION

1. Operator to interrupt power supply, and reconnect.
2. The unit should automatically start bacteria flushing and auto-restore to standby.
3. When this indication returns immediately after resetting the temperature of the feed water is still too high and has to drop below the temperature threshold.

4. When the feed water temperature has dropped below 40°C the interrupting and restoring the power supply should result in bacteria flushing and auto-restore to standby.

NOTE:

High feed water temperatures lead to a significantly increased deterioration of the membrane, but does not influence the quality of the water produced.

Servicing the system

PRE-FILTRATION INSERTS

The replacement intervals are dependent on the degree of water contamination and total quantity produced by the system and should be replaced at least every six month in order to protect the membrane. To keep track of the replacement intervals it is advised to keep a record of the replacements.

HOW TO REPLACE THE PRE-FILTRATION INSERTS

1. Disconnect the power supply. Close off the feed water supply.
Depressurise the pre-filter housings by opening the vent plugs (See Fig. 1a).
The filtration inserts are fitted inside the plastic bowls fitted to the pre filter unit.
2. Access to the filtration inserts is gained by removing the locking ring that holds the transparent filter container by rotating it clockwise.
3. Carefully remove the plastic container with the insert in it and empty the water out in the sink. Place a bucket underneath the pre-filter unit to avoid spillage.
4. Remove the filter insert and clean the inside of the transparent container with water.
5. Unpack the new filter insert, and place in the container. The particle filter can be fitted with either side up, the carbon filter (black) needs to be fitted with the seal on one end pointing upwards as shown in figure 1b on page 5.
6. Place the plastic container holding the new filter insert back in its original location and tighten the assembly with the locking ring that holds the transparent filter container by rotating it counter clockwise.
7. Open the feed water supply again.

Make sure both vent plugs on the filtration housing are (still) open, and let air trapped in the filter run out, until water without any air comes from the ventilation holes.

8. Close both vent plugs by hand force only.
9. Check for possible leaks resulting from changing the membrane.
10. When no leaks are observed, initiate a commissioning procedure.
11. The machine is ready for normal use again.

MINERAL CARTRIDGE EXCHANGE AND RESET

1. Disconnect the power supply.
2. Open the faucet until the water stops flowing.
3. Click out the existing mineral cartridge replace it with the new cartridge. Be aware some water may come out.
4. Check if the tap is still open.
5. Connect the power supply again. The system will directly perform a flush. To reset the remin counter in the machine, please click the black button at the back of the machine, 3 times within 1 second.
6. Let the faucet run for 2 minutes then close the faucet.

MEMBRANE FILTER

The replacement intervals are dependent on the degree of water contamination and will typically vary between one and two years. To keep track of the replacement intervals it is advised to scan the NFC chip and let the aquablu App show you when to replace the filters. If suddenly the replacement intervals significantly shorten, it is advised to contact your local dealer.

HOW TO REPLACE THE MEMBRANE FILTER INSERT

1. Close off the feed water supply.
2. Depressurize the system by opening the water faucet. A “low pressure” alarm will be given by the system when the system is depressurized (indicated by a red light on the faucet and red single flash on the unit in combination with a quick sound from the purification unit).
3. Close the faucet.
4. Disconnect the electrical power supply to the purification unit.
5. Move the purification unit as far as your piping allows out of the cabinet and prepare a drip tray. Expect 0.5 liter of water coming out of the membrane vessel.
6. The membrane filter is mounted in a stainless steel tube that is an integral part of the purification unit frame.
7. Access to the membrane is gained by first removing the round plastic outer cover on the front of the purification unit by rotating it counter clock wise. Inside this plastic cover a small key-wrench is placed, see figure 20 below.

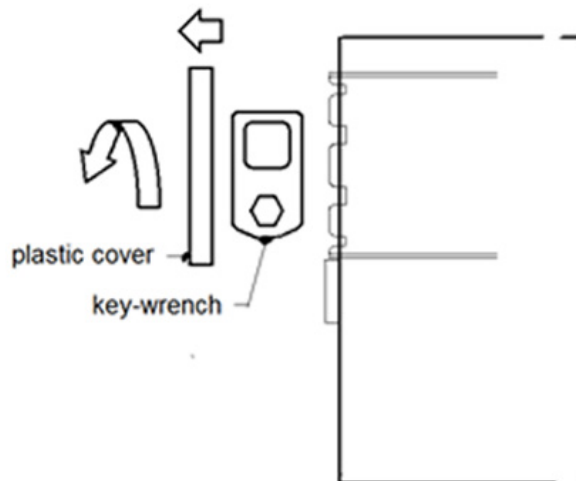

Fig. 21: Removal of front cover and key-wrench

8. After removing the plastic cover the stainless steel locking plate is visible. On the locking plate a hexagon nut is visible, which should be completely removed with the key-wrench, or another properly fitting wrench.

9. After the nut is removed, the locking plate must be rotated counter clock wise to be released from the locking tabs in the membrane housing and withdrawn from the unit. See figure 22 below:

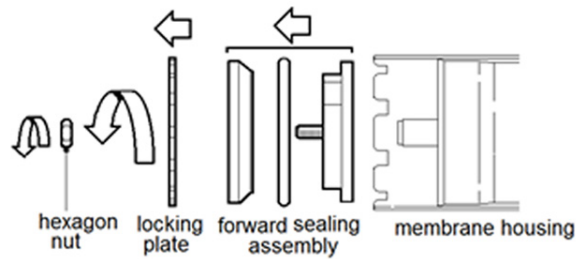

Fig. 22: Removal of locking plate and membrane chamber seal assembly

10. After removing the locking plate, the membrane chamber seal assembly is visible, and should also be withdrawn from the unit. Please note that approx. 0,5 liter of water is still in the unit and will be released when the end cap is removed. Place all parts in a secure and clean location for refitting later.
11. After removal of the membrane seal assembly, the membrane itself is visible. Place the square aperture in the key-wrench over the grey tube at the front of the membrane and place it in such an angle that the edges of the key-wrench bite into the surface of the tube. The membrane should be pulled forward up to the edge of the locking cams in the front of the membrane housing. A slight resistance will be felt as the sealing lip of the membrane reaches the locking cam edge.
12. With the key-wrench firmly locked on the membrane tube, the membrane should be pulled out of the membrane housing with a rotating pull movement. With the lip seal free of the membrane housing the membrane can be pulled out further without any effort. See figure 23 below for the membrane removal sequence.

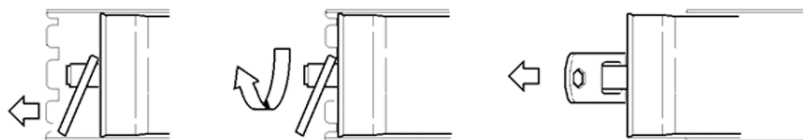

Fig. 23: Removal sequence of the membrane

Put the old membrane aside for discarding. If difficulties are encountered with removing the membrane as described, a pipe wrench or suitable pair of pliers may be used.

When placing the new membrane into the unit, care must be taken to insert the membrane into the unit in the correct way. On the membrane an arrow is placed, the membrane should be inserted in the direction of the arrow. In case of doubt, see figure 24 for the correct membrane position.

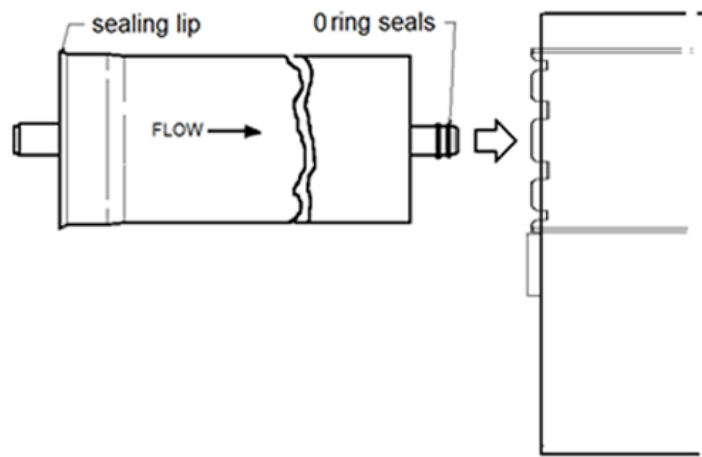

Fig. 24: Correct direction of membrane installation

13. Unpack the new membrane, and install in the correct manner. Push the membrane all the way back in the chamber. Some resistance can be felt with the membrane almost in position when the O ring seals enter the pick-up tube in the rear of the membrane chamber. The membrane must be fully pushed home until a clear end stop is noticed.
14. Clean and refit the stainless steel locking
15. Refit and tighten the securing, taking care not to over tighten. Check for leaks once the system has been restarted.
16. Open the feed water supply again and reconnect the power supply to the machine.

The machine will enter the commissioning mode. Look in the chapter “commissioning” for an explanation of this procedure.

HOW TO PROPERLY STORE A WORKING MEMBRANE FILTER

When the Aquablu unit is not connected to power supply for a longer period of time, the membrane should be taken out and stored properly to avoid contamination and termination of the membrane. No power supply means the system cannot take care of the membrane itself as no automatic back flush can be performed. Figure 25 shows the steps to be taken to store the membrane properly.

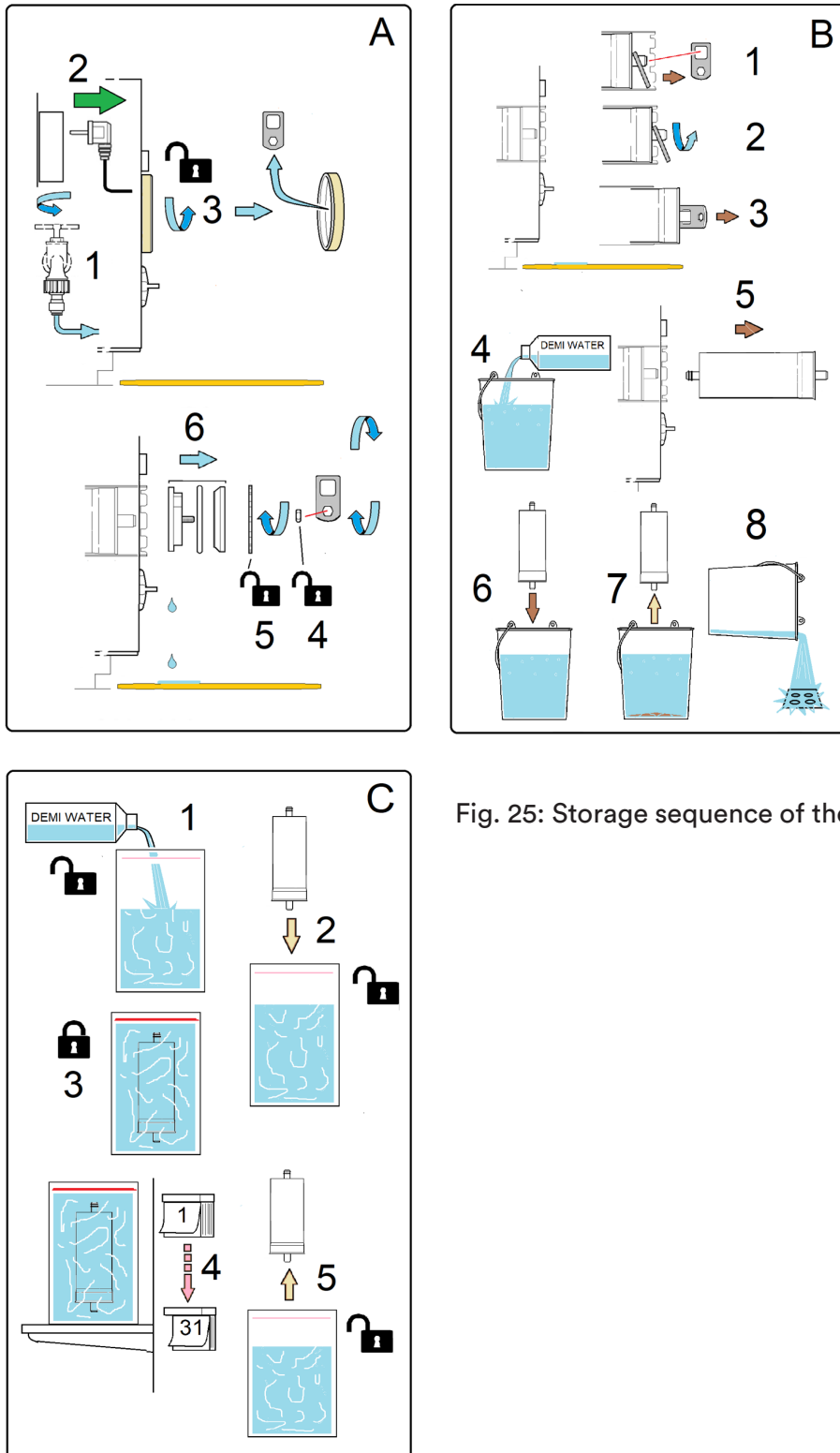

Fig. 25: Storage sequence of the membrane

Decommissioning the system

At the end of its serviceable life, the system as whole or individual parts that have become unserviceable must be decommissioned and discarded in a responsible manner. The system is simply decommissioned by disconnecting it first from the mains electricity supply, then from the mains water supply. Empty the system, and take out the filter cartridges and the membranes, and discard these separately. Most of the materials and assemblies used in the system can be recycled due to their design and the materials used. Take the system or the involved part(s) to the municipal/district recycling yard, a commercial recycling company, or return the system to the dealer who will take care of this.

Technical Data

The system is designed to operate within the limits listed in the table below:

Max. Operating pressure	6 bar
Minimum ambient temperature	+5°C
Maximum ambient temperature	+45°C
Maximum feed water temperature	+45°C
Chlorine concentration	< 0,1 ppm
Water Turbidity	1 NTU
Max. TDS** inlet water at membrane	< 1200 ppm*** (2500 uS/cm****)
Max. TDS** inlet water at pre-filter	Depending on pre-filter configuration
Minimum Input Pressure	1,5 bar
Maximum Input pressure	3 bar
Purified water volume at 25°C	50 to 120 liters a hour
Max. Hardness	180 mg CaCO ₃ /L or 10°DH

*NTU = Nephelometric Turbidity Units

**TDS = Total Dissolved Solids

*** PPM = Parts per million

**** uS/cm = Microsiemens per centimeter

Warranty Card & Serial Number:

Manual version:
1001

Warranty

Every Aquablu product is carefully designed to ensure excellent quality and optimal customer experience. Unfortunately, the situation can occur that your purifier does not work as it's supposed to.

In case this is a result from product failure, we will correct, free of charge, any defects in material (excluding replacement filters and membranes) or workmanship for a period of 24 months subject to the terms and conditions mentioned in this statement.

When properly installed and maintained, your Aquablu will give years of outstanding performance and service. Must something occur, the Aquablu Service team and certified Aquablu Dealers are always at your disposal.

A. Services included

Adding to the correction of defects in material or workmanship during the warranty period, and subject to exclusions mentioned in this statement, Aquablu agrees to correct the cost of repair of parts and labour. Any parts replaced during the repair will become the property of Aquablu. If in the opinion of Aquablu, a water purifier is beyond economic repair, Aquablu reserves the right to provide customers with a new product of equivalent specification. If Aquablu replaces the product, the warranty will become invalid.

B. Exclusions

In the event any of the following matters result in system failure to, Aquablu will reject any warranty claim and its complementary costs:

- Non-compliance with safety regulations and warnings given in the operating instructions.
- Faults caused by the user through operating errors or lack of care and maintenance.
- Non-domestic, commercial or inside (in home) use.
- Intentional damage by the owner or third parties.
- Incorrect installation, including but not limited to not meeting feed water requirements.
- Faulty repairs or repairs carried out by parties other than Aquablu or an Authorized Aquablu technician.
- External influences (e.g. fire, flooding, freezing, pressure spikes, weather, transit damage)
- Replacement parts subject to wear and tear e.g. filters.
- Visual blemishes such as marks and dents.
- Use of non-approved accessories, filters, membranes or spare parts.
- Damage to accessories.
- Accidental damage.

C. Claims Procedure

I. only applies for the Aquablu One and Pro

- I. Check the Aquablu App during troubleshooting. This enables your Authorized Aquablu Dealer to get insight into the technical status of your system.

1. Contact your authorized Aquablu dealer by whom you have purchased the product.
2. The dealer will request the proof of purchase (invoice, checkout receipt or similar including, date, vendor, price and conditions) or proof of ownership (copy of warranty registration app).
3. After reviewing 2), the Dealer or service partner will issue a Claims Authorization Number (CAN) if the warranty conditions are met. No claims will be accepted without a CAN.
4. Depending on the situation, the product will either be serviced on location by an Authorized Service Technician or brought/sent to an Authorized Service Station for repairs. Aquablu will only bear repair costs carried out by Aquablu's network of Authorized Service Providers. If during a service visit, no fault can be found for which Aquablu is responsible according to this policy, customers will be invoiced with call-out charges, and labour costs of 60 minutes in accordance with Aquablu's standard rates for the time being.

D. Liability

Aquablu assumes no warranty liability in connection with Aquablu water purifier systems other than specified herein. This Warranty is in lieu of all other warranties, expressed or implied, including warranties of fitness for a particular purpose. Aquablu does not authorize any person or representative to assume for us any other obligations on the sale of an Aquablu water purifier system.

Aquablu shall not be liable for loss of goods, loss of use, or any special, indirect, or pure economic loss, costs, damages, charges or expenses except for liability that Aquablu is not allowed to exclude by law. This Warranty gives you specific legal rights, and you may also have other rights, which vary from country to country, state to state or province to province. The laws of some jurisdictions do not permit the exclusion or limitation of certain rights or remedies provided by such laws.

As this Warranty is subject to such laws, some of the limitations or restrictions contained in this Warranty may not apply to you. The provisions of this Warranty are in addition to and not a modification of or subtraction from the statutory warranties contained in country, state or provincial laws. Some states or provinces do not allow limitations on how long an implied warranty lasts, so the above limitation may not apply to you.

Declaration of conformity

Producer

Name: Aquablu
Address: 's Gravendamseweg 53, 2215TC Voorhout, the Netherlands

Details

Equipment: Water treatment solutions
Model types: One, Pro, Custom
Tradenames: Aquablu

Reviewed Guide lines and standards

1. Equipment guide line 2006/42/EC (EN12100)
2. LVD guide line 2006/95/EC (EN60204-1, NEN3140, (NEN1010)
3. EMC guide line 2004/108/EC (EN55011)
4. PED guide line 97/23/EG
5. DWD guide line 98/83/EG

Additional information

All components are applicable for drinking water. This is checked bij Euronorm Legislation & Norms and tested by Manitronica S.r.l. Report #221216A. The equipment is for the production of drinking water.

Declaration

Hereby I declare that above mentioned equipment meets the guide lines and standards mentioned in this declaration.

Name: M.J.P. Stokvis, CEO Date: 01/01/2020

.....
signature of authorized representative

The small print

Conformity

All filtering systems are developed and built in compliance with all applicable EU regulations regarding health and safety requirements, and carries a CE marking. All electric and electronic components are in compliance with the Low voltage directive 2006/95/EEC and the Electromagnetic Compatibility Directive 2004/108/EEC.

The system also complies to ISO 4000 and ruling EC 1275/2008 for energy conservation.

Intellectual Property

The Aquablu brand name, the filtering system, models, drawings, engineering and documentation are the exclusive property of the Stokvis Holding in Voorhout. It is expressly forbidden to copy, use or hand over such information to third parties without prior, specific written permission.

Product liability

The manufacturer declines all liability in case of:

- Use of the filtering system in contradiction with local health and safety laws or regulations.
- Incorrect installation, disregard or incorrect application of the instructions in this manual.
 - Incorrect or faulty electrical power supply.
 - Modification or tampering.
 - Operation of the system with saline or brackish water.
- Work carried out on the filtering system by non-qualified or unsuitable persons.

Disclaimer

Aquablu Innovative purification solutions reserves the right to modify, upgrade or improve their products at any moment without advance notice and will not be liable for any difference between actual unit supplied and the latest specifications stated in the sales material or the user manual. Contact the Aquablu Innovative purification solutions technical department in case extra information is required, for example, maintenance and repair. This User Manual has been created with great care, however Aquablu Innovative purification solutions cannot be held responsible for errors in this publication or for the impact of any of these possible errors. This User Manual has been written and published by Aquablu Innovative purification solutions in Voorhout

To all our deliveries the general delivery conditions of the Federation of Metal and Electro technical Industries (F.M.E.) as deposited in December 2010 at the district court in The Hague are applicable, apart from those articles for which alternative or complementary provisions have been included.

BECOME PART OF THE #AQUABLU FAMILY

Our systems are made with care in order to supply you and your family with perfectly safe and healthy drinking water. By using only the highest quality materials, our systems will easily last for decades. After installation, you will experience the convenience of having an Aquablu system at home. Aquablu's purifiers are no ordinary purifiers. They can truly be relied upon as a friend. We deliver a maximum of one filter package per installation.

Share your

Aquablu experience on Instagram by tagging

@aquablu.solutions and receive a free pre-filtration filter package! *

*this offer can only be redeemed once

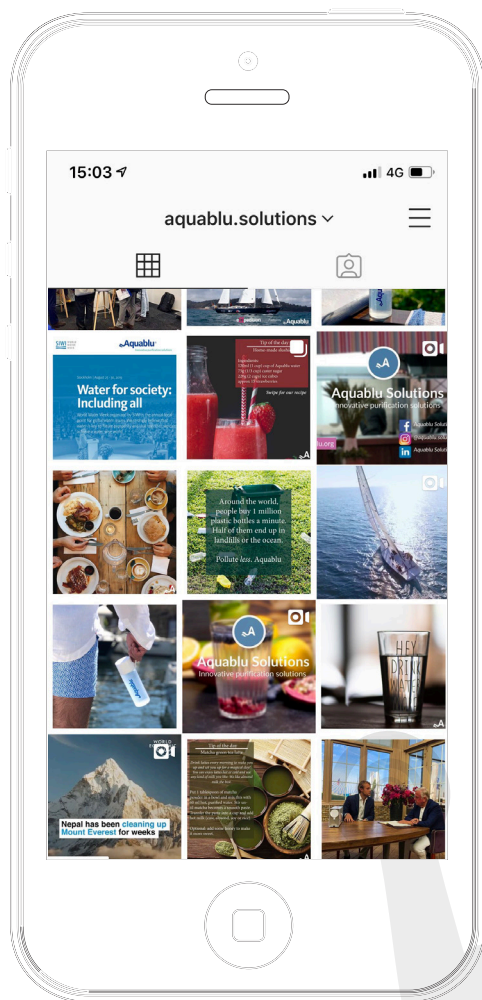

@aquablu.solutions
#Aquablufamily

The logo for Aquablu features a stylized blue wave icon to the left of the brand name "Aquablu" in a bold, dark blue sans-serif font.

Just pure, even better.

member of Stokvis Group